

Parallel Shaft Mounted Gear Units D/M Series

Technic Selection	
Type	D
Input Option	Without Motor
Assembly Shaft Design	HOLLOW SHAFT
Body Size	603
FA Press [N]	6000
FA Pull [N]	6000
FR [N]	11200
Frequency [Hz]	50
fs	0.9
iges	343.64
M2 [Nm]	3305
M2max [Nm]	3000
Motor Efficiency	IE2
Motor Size	90/4P
n1 [rpm]	1400
n2 [rpm]	4.1
P1 [kW]	1.5
P1max [kW]	1.36

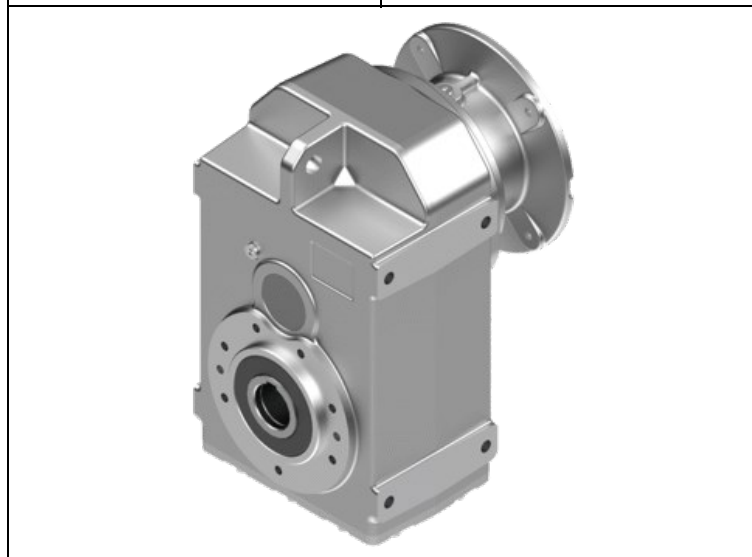

Variation	
Input Connection Type	PAM
Input Backstop Status	Without Backstop
Input Connection Size	PAM-90-B5
Output Shaft Diameter	ØD=Ø60H7[mm]
Mounting Position	M1

Option	
Oil Status	Exist
Oil Type	Mineral ISO VG 220
Vent Plug	Standard
Oil Indicator Plug	None
Product Label	Standard
Color	RAL 7000
Montage Position Status	Standard
Amount Of Oil [Liter]	15,6
Case Material	GGG-40
Reinforced Bearing Status	None
Output Oil Seal Type	NBR
Output Bearing Quality	Standard

D 602-603

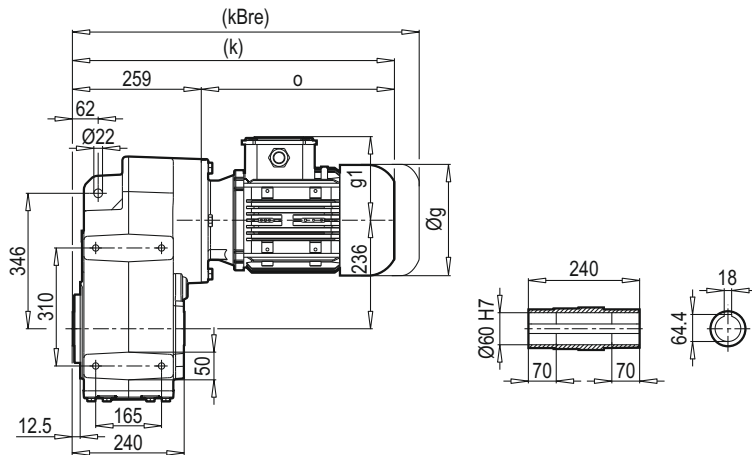

D 602-603...B14

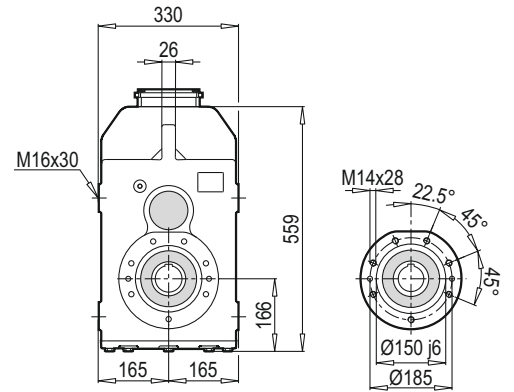

M 602-603

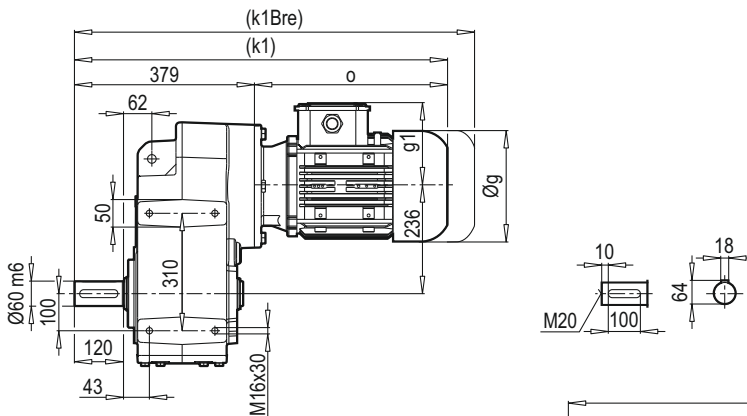

M 602-603...B14

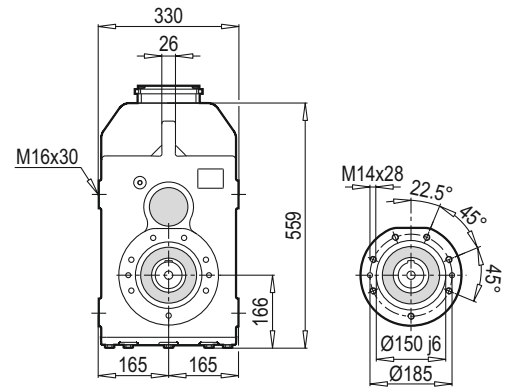

D/M 602-603...B5

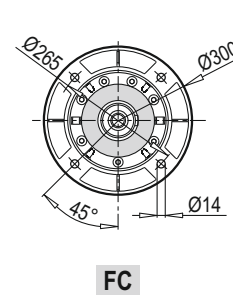
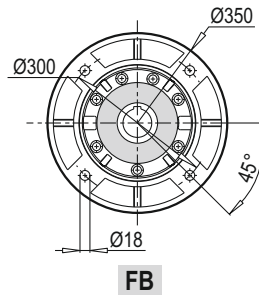
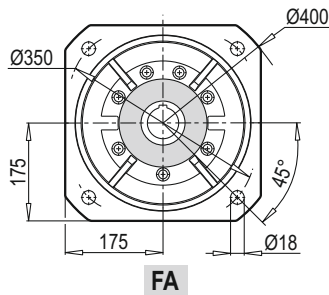
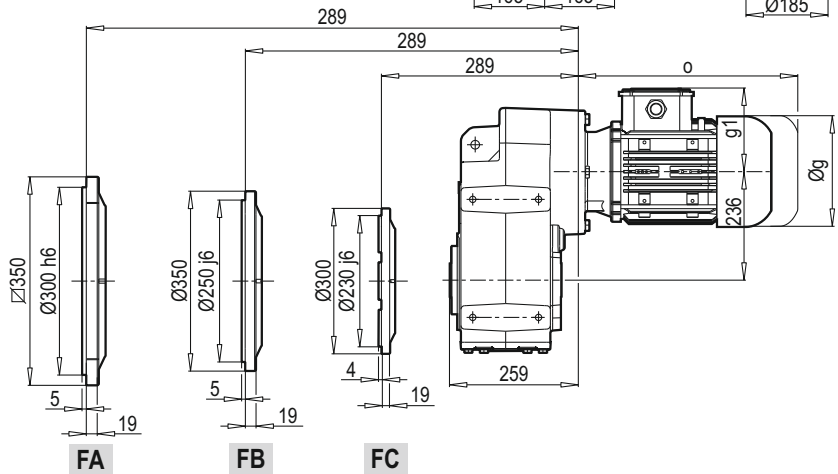
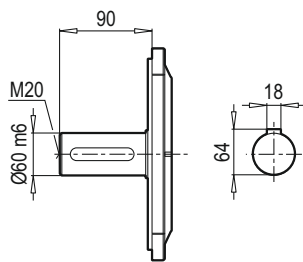

	80M	90S	90L	100L	112M	132S	132M	160M/L	180M/L	200L
g	159	193	193	217	232	279	279	323	370	415
g1	127	151	151	160	168	182	182	200	248	260
k/k1	517/637	542/662	562/682	585/705	639/759	645/765	680/800	767/887	832/952	869/989
kBre/k1Bre	579/699	615/735	635/755	666/786	719/839	753/873	821/941	919/1039	994/1114	1016/1136
o	258	283	303	326	380	386	421	508	573	610

D 602-603 PAM B5/B14

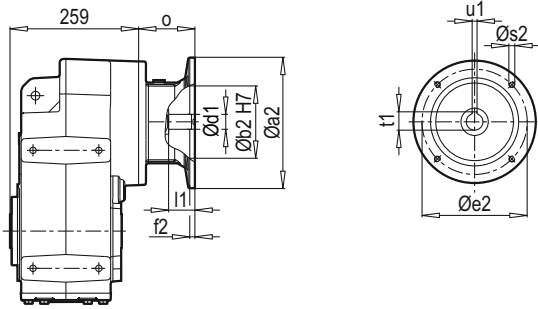

D 602-603 W

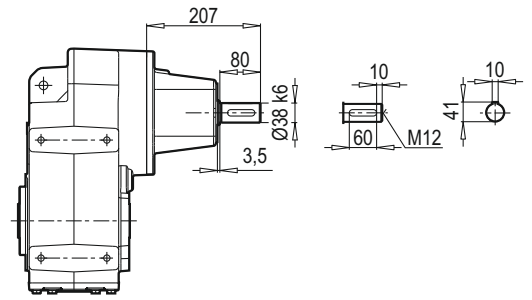

M 602-603 PAM B5/B14

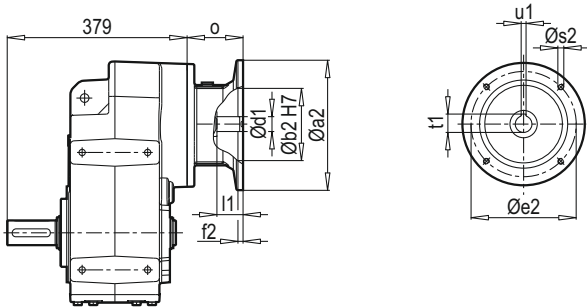

M 602-603 W

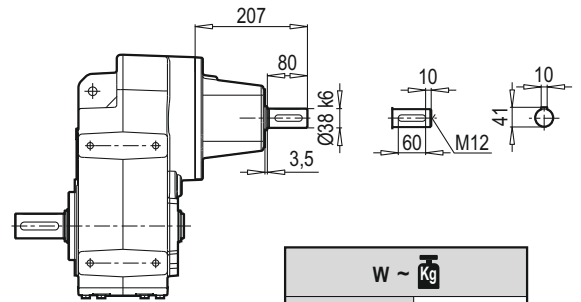

W ~ Kg	
D/M 602 - 603	92

D/M 602-603 B5 PAM B5/B14

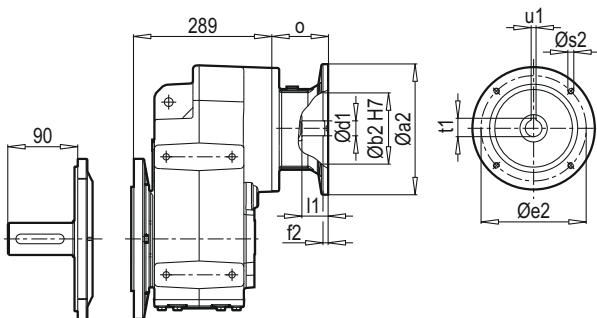

D/M 602-603 B5 W

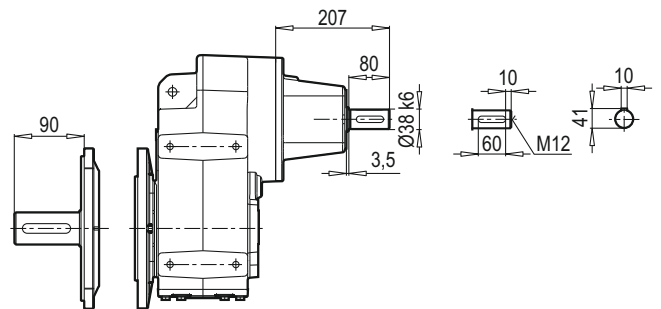

Typ / Type / Tipo Type / Tipo	PAM B5	Øa2	Øb2	Øe2	f2	Øs2	Ød1	l1	t1	u1	o
D/M 602 - 603	80	200	130	165	5	10	19	42	21.8	6	61
	90	200	130	165	5	10	24	52	27.3	8	61
	100	250	180	215	5.5	12	28	62	31.3	8	76
	112	250	180	215	5.5	12	28	62	31.3	8	76
	132	300	230	265	5.5	12	38	82	41.3	10	101
	160	350	250	300	7	16	42	112	45.3	12	148
	180	350	250	300	7	16	48	112	51.8	14	148
	200	400	300	350	7	16	55	112	59.3	16	185

~ Kg		
PAM B5	D/M 602	D/M 603
80	83	83
90	83	83
100	87	87
112	87	87
132	90	90
160	96	-
180	96	-
200	112	-

Typ / Type / Tipo Type / Tipo	PAM B14	Øa2	Øb2	Øe2	f2	Øs2	Ød1	l1	t1	u1	o
D/M 602 - 603	80	120	80	100	3	7	19	42	21.8	6	61
	90	140	95	115	3	9	24	52	27.3	8	61
	100	160	110	130	3.5	9	28	62	31.3	8	76
	112	160	110	130	3.5	9	28	62	31.3	8	76
	132	200	130	165	3.5	11	38	82	41.3	10	101

~ Kg	
PAM B14	D/M 602 - 603
80	80
90	80
100	82
112	82
132	88