

# General Catalogue



**Gearboxes Made in Italy**



®

**HYDRONEMA**

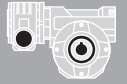

#### QUICK SELECTION / Selezione veloce

input speed ( $n_1$ ) = 1400 min<sup>-1</sup>

Output Speed $n_2$ [min <sup>-1</sup> ]	Ratio $i$	Motor power $P_{1M}$ [kW]	Output torque $M_{2M}$ [Nm]	Service factor f.s.	Nominal power $P_{1R}$ [kW]	Nominal torque $M_{2R}$ [Nm]	Available B5 motor flanges		Available B14 motor flanges			Dynamic efficiency RD	Tooth Module [mm]	Ratios code
							-B	-C	-O	-P	-Q			
							63	71	56	63	71			
5.6	<b>252</b>	0.25	198	1.3	<b>0.33</b>	<b>265</b>	<b>B</b>		B-C	B-C		46	2.7	01
3.9	<b>360</b>	0.18	186	1.4	<b>0.26</b>	<b>265</b>	<b>B</b>		B-C	B-C		42	2.7	02
2.8	<b>504</b>	0.18	241	1.1	<b>0.20</b>	<b>265</b>	<b>B</b>		B-C	B-C		39	2.7	03
1.9	<b>756</b>	0.12	204	1.3	<b>0.16</b>	<b>265</b>	<b>B</b>		B-C	B-C		33	2.7	04
1.4	<b>1008</b>	0.12	256	1.0	<b>0.12</b>	<b>265</b>	<b>B</b>		B-C	B-C		31	2.7	05
1.1	<b>1332</b>	0.12*	265	<0.8	<b>0.10</b>	<b>265</b>	<b>B</b>		B-C	B-C		30	2.7	06
0.8	<b>1656</b>	0.12*	265	<0.8	<b>0.08</b>	<b>265</b>	<b>B</b>		B-C	B-C		28	2.7	07
0.6	<b>2160</b>	0.12*	265	<0.8	<b>0.07</b>	<b>265</b>	<b>B</b>		B-C	B-C		26	2.7	08
0.6	<b>2520</b>	0.12*	265	<0.8	<b>0.06</b>	<b>265</b>	<b>B</b>		B-C	B-C		25	2.7	09

**Motor Flanges Available**  
Flange Motore Disponibili

**B) Supplied with Reduction Bushing**  
Fornito con Bussola di Riduzione

**B) Available on Request without reduction bushing**  
Disponibile a Richiesta senza Bussola di Riduzione

**C) Motor Flange Holes Position**  
Posizione Fori Flangia Motore

\* Power higher than the maximum one which can be supported by the gearbox. Select according to the torque  $M_{2R}$   
Potenza superiore a quella massima sopportabile dal riduttore. Selezionare in base al momento torcente  $M_{2R}$

**EN** Unit 634 is supplied with synthetic oil, providing "long life" lubrication. For mounting position V5-V6 please contact us. See table 1 for lubrication and recommended quantity. In table 2 please see possible radial loads and axial loads on the gearbox.

**I** Il riduttore tipo 634 viene fornito lubrificato a vita con olio sintetico. Per posizioni V5-V6 contattare il ns. servizio tecnico. Vedi tab.1 per oli e quantità consigliati. In tab.2 sono presenti i carichi radiali e assiali applicabili al riduttore.

**D** Für die Lebensdauerschmierung ist das Getriebe der Größe 634 mit synthetischem Öl befüllt. Bei Einbaulage V5 oder V6 bitten wir um Rücksprache. In Tabelle 1 ist die Schmiermenge und das empfohlene Schmiermittel angegeben. In Tabelle 2 sind die zulässigen Radial- und Axialbelastungen des Getriebes aufgeführt.

**F** Le réducteur de type 634 est fourni lubrifié à vie avec de l'huile synthétique. Concernant les positions V5.V6, contactez notre service d'assistance technique. Voir tableau 1 concernant les huiles et les quantités conseillées. Les charges radiales et axiales applicables au réducteur sont précisées dans le tableau 2.

**E** El reductor tamaño 634 se suministra, lubricado de por vida con aceite sintético. Para las posiciones V5 y V6 contactar con nuestro servicio técnico. Ver tabla 1, para cantidades y aceites recomendados. En la tabla 2, se encuentran las cargas radiales y axiales admitidas por el reductor.

**LUBRICATION 634 Oil** 0.40 Lt. 0.09 Lt.

**Quantity 0.40/0.09 Lt.**

**AGIP** Telium VSF 320      **SHELL** Omala S4 WE 320

For all details on lubrication and plugs check our website **tab. 1**  
Per maggiori dettagli su lubrificazione e tappi olio vedi il nostro sito web

#### RADIAL AND AXIAL LOADS

##### Output shaft

Albero di uscita

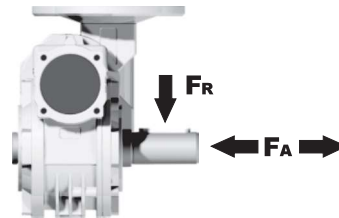

$n_2$ [min <sup>-1</sup> ]	FA [N]	FR [N]
25	700	3800
15	800	4000

##### Input shaft

albero in entrata

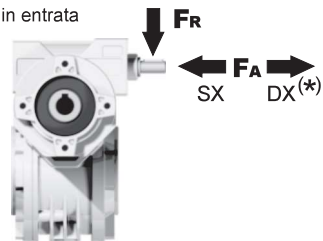

$n_1$ [min <sup>-1</sup> ]	FA [N]	FR [N]
1400	42	210

\*Strong axial loads in the DX direction are not allowed.  
Non sono consentiti forti carichi assiali con direzione DX

tab. 2

3D dimensions on request

P634FB...

Basic wormbox  
Riduttore base

Gearbox weight  
peso riduttore **8.90 kg**

M. flanges	Kit code	øF	A
63B5	K050.4.041	138	74
71B5	K050.4.042	160	71.5
56B14	KC40.4.049	80	71.5
63B14	K050.4.047	90	74
71B14	K050.4.045	105	71.5

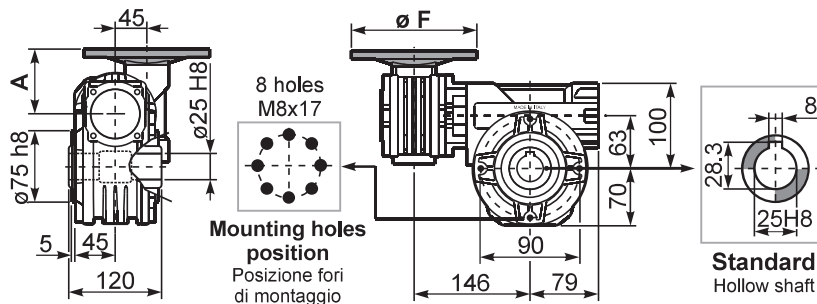

P634PA...

Feet  
Piedini

P634PB...

Feet  
Piedini

P634PV...

Feet  
Piedini

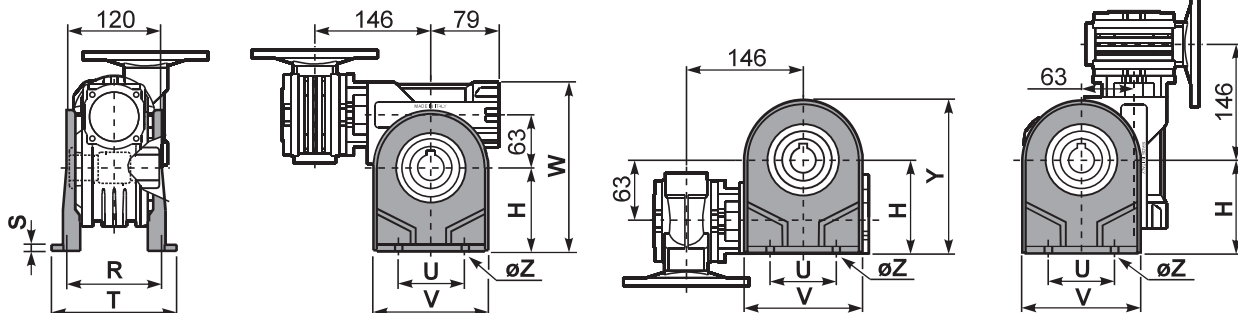

	H	R	S	T	U	V	Y	W	øZ	kit code
type B	100	111	4	144	95	133	170	200	ø10.5	K063.9.022
type S	-	-	-	-	-	-	-	-	-	-

P634FC...

Output flange  
Flangia uscita

P634BR...

Reaction arm  
Braccio di reazione

kit cod. K063.9.027

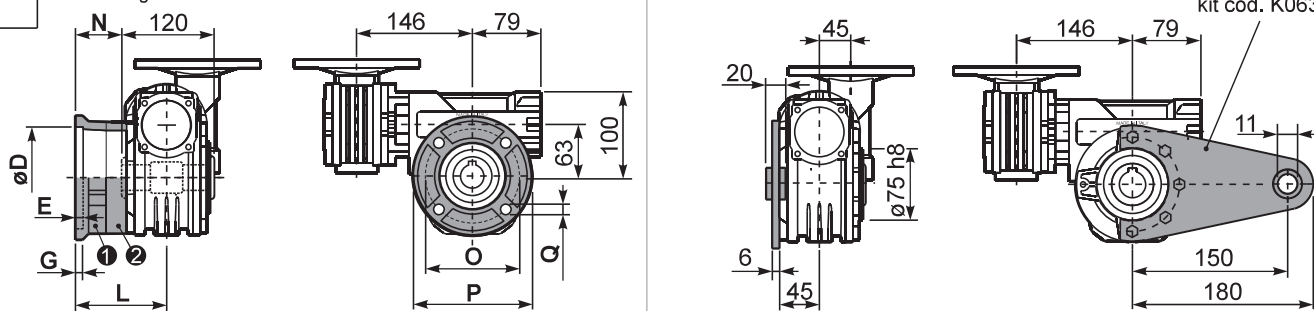

type B	øD	E	G	L	N	O	P	Q	kit code
FC	115 <sup>+0.20</sup> / <sub>+0.15</sub>	7	13	86	26	150	175	11	① K063.9.010 ② -
FL	115 <sup>+0.20</sup> / <sub>+0.15</sub>	7	13	116	56	150	175	11	① K063.9.010 ② K063.0.200

type S	øD	E	G	L	N	O	P	Q	kit code
F1	130 <sup>+0.20</sup> / <sub>+0.15</sub>	7	13	102	42	165	200	13	① KS070.9.013 ② -
F2	115 <sup>+0.20</sup> / <sub>+0.15</sub>	7	13	116	56	150	175	11	① KS063.9.013 ② -
F3	110 <sup>+0.035</sup> / <sub>0</sub>	5	11	82	22	130	160	10	① KS063.9.011 ② -

P634.....S...

Single Shaft  
Albero lento semplice

P634.....D...

Double Shaft  
Albero lento bisp.

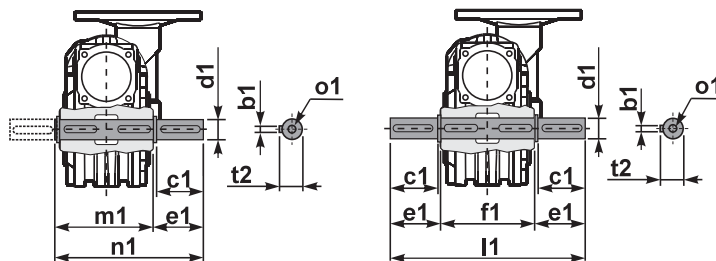

① kit cod. K063.5.028 type B

② kit cod. K063.5.029 type B

R634FB...

Input shaft  
Albero in entrata

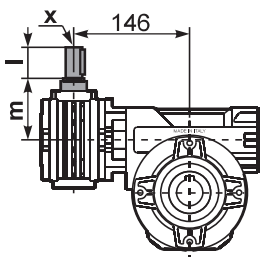
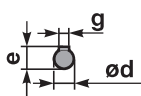

	ød	e	g	l	m	x	kit code
type B	11 h6	12.5	4	30	68	-	① K045.5.006 PAM71 ② -
type S	-	-	-	-	-	-	① - ② -

	b1	c1	d1	e1	f1	l1	m1	n1	t2	o1
type B	8	60	25 <sup>-0.005</sup> / <sub>-0.020</sub>	63.2	120	246.4	126.8	190	28	M8x20
type S	-	-	-	-	-	-	-	-	-	-